

ECLIPSE[®]

Enhanced Model 705 with
PROFIBUS PA[™] Digital Output

705 software v3.x

PROFIBUS PA[™] Operating Manual

*Guided Wave Radar
Level Transmitter*

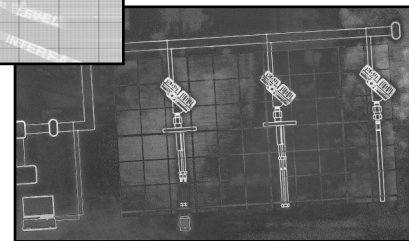

Use in conjunction with
I&O manual BE 57-600





PROFIBUS PA™ Enhanced Eclipse Model 705 Guided Wave Radar Transmitter

Table of Contents

1.0 PROFIBUS PA™ Overview	3
1.1 Description.....	3
1.2 Benefits.....	4
1.3 Device Configuration.....	4
1.4 Intrinsic Safety.....	5
2.0 QuickStart Configuration	7
3.0 Function Blocks	8
3.1 Overview.....	8
3.1.1 Standard Profibus Block Parameters.....	8
3.2 Physical Block.....	9
3.3 GWR Transducer Block.....	11
3.3.1 GWR Transducer Block Parameters.....	11
3.3.2 Password Parameters.....	12
3.3.3 Configuration Parameters.....	13
3.3.4 Offset Description.....	14
3.4 Calibration Parameters.....	15
3.4.1 Factory Parameters.....	15
3.4.2 Firmware Version.....	15
3.5 Analog Input Block.....	16
3.5.1 AI Block Parameters.....	16
3.5.2 Local Display of Analog Input Block Output Values.....	17
3.5.2.1 AI Out Display Screens.....	18
4.0 Model 705 Menu: Step by Step Procedure	19
5.0 Diagnostic Parameters	21
5.1 Simulation Feature.....	22
6.0 Reference Information	23
6.1 Troubleshooting.....	23
6.1.1 Troubleshooting System Problems.....	23
6.1.2 Device Status Parameter in the Transducer Block.....	24
6.1.3 Error Mapped to Diagnosis.....	25
6.1.4 PROFIBUS PA™ Segment Checklist.....	26
6.2 References.....	27
Appendix	28
Configuration Data Sheet	29

1.0 PROFIBUS PA™ Overview

1.1 Description

PROFIBUS PA™ is a digital communications system that serially interconnects devices in the field. A fieldbus system is similar to a Distributed Control System (DCS) with two exceptions:

- Although a PROFIBUS PA™ system can use the same physical wiring as an existing 4–20 mA device, fieldbus devices are not connected point to point, but rather are multidropped and wired in parallel on a single pair of wires (referred to as a segment).
- PROFIBUS PA™ is a system that allows the user to distribute control across a network. Fieldbus devices are smart and actually maintain control over the system.

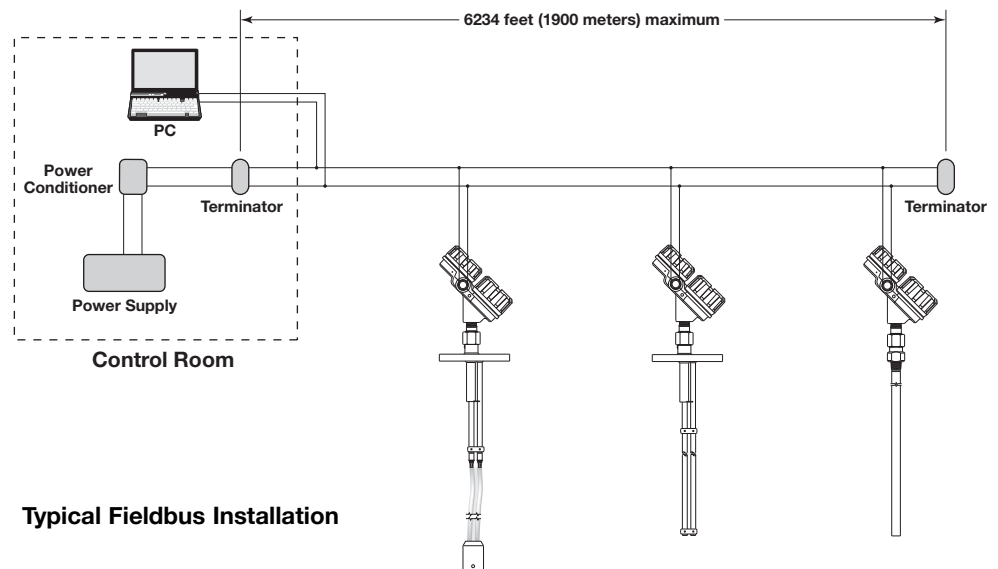

Typical Fieldbus Installation

Unlike 4–20 mA analog installations in which the two wires carry a single variable (the varying 4–20 mA current), a digital communications scheme such as PROFIBUS PA™ considers the two wires as a network. The network can carry many process variables as well as other information. The Enhanced Eclipse Model 705PA transmitter is a PROFIBUS PA™ certified device that communicates with the DPV1 protocol operating at 31.25 kbits/sec. The MBP physical layer is an approved IEC 61158 standard.

An IEC61158 shielded twisted pair wire segment can be as long as 1900 meters (6234 feet) without a repeater. Up to 4 repeaters per segment can be used to extend the distance. The maximum number of devices allowed on a fieldbus segment is 32 although this depends on the current draw of the devices on any given segment.

Details regarding cable specifications, grounding, termination, and other network information can be found in IEC 61158 or the technical guideline “PROFIBUS PA™ User and Installation Guideline” at www.profibus.com.

1.2 Benefits

The benefits of PROFIBUS PA™ can be found throughout all phases of an installation:

1. **Design/Installation:** Connecting multiple devices to a single pair of wires means less wire and fewer I/O equipment. Initial Engineering costs are also reduced because PROFIBUS International requires interoperability, defined as “the ability to operate multiple devices in the same system, regardless of manufacturer, without a loss of functionality.” All PROFIBUS PA™ devices must be tested for interoperability by a PI accredited, independent testing agency. Magnetrol Model 705PA device certification information can be found at www.profibus.com.
2. **Operation:** A PROFIBUS PA™ system allows for multiple variables to be brought back from each device to the control room for additional trending and reporting.
3. **Maintenance:** The self-diagnostics residing in the smart field devices minimizes the need to send maintenance personnel to the field.

1.3 Device Configuration

The function of a PROFIBUS PA™ device is determined by the arrangement of a system of blocks. The types of blocks used in a typical User Application are described as follows:

Physical Block describes the characteristics of the PROFIBUS PA™ device such as the device name, manufacturer, and serial number.

Function Blocks are built into the PROFIBUS PA™ devices as needed to provide the desired control system behavior. There can be numerous function blocks in a single User Application.

Transducer Blocks contain information such as calibration parameters and sensor type. They are used to connect the sensor to the input function blocks.

An important requirement of fieldbus devices is the interoperability concept mentioned earlier. Device Description (DD) technology can provide extended descriptions for each object and provides pertinent information useful for a host system.

DDs are similar to the drivers that your personal computer (PC) uses to operate peripheral devices connected to it.

General PROFIBUS Information:

- The Model 705 supports PA Profile Version 3.0
- The Ident Number issued by the PNO for Magnetrol Model 705 3.x is 0x09B3. The Ident Number is included in the name of the GSD file.
- The General Station Description (GSD) file provides information on the features and performance capabilities of a PROFIBUS device to allow easy configuration of PROFIBUS networks with devices from different manufacturers. The manufacturer-specific GSD file for PA Model 705 3.x is Mag_09B3.gsd. Also, a bitmap file specified in the GSD file provides a symbolic representation of the device for network configuration tools.
- The Model 705 3.x can also use the profile-specific GSD file PA139703.gsd. If this general GSD file is used, the “Ident number Selector” parameter in the Physical Block must be set to the profile-specific ident number. The default selection of the “Ident Number Selector” parameter is the manufacturer-specific ident number.
- A Device Description is available for configuring the device using Simatic PDM.
- The range of device bus addresses is 0 to 126. 126 is the default address and all units will ship with address 126 unless a non-default address assignment is requested by the customer. The address can be changed via the fieldbus or the local LCD interface.

Additional information can be found at www.profibus.com.

1.3.1 PROFIBUS DD Revision Table

Model 705 3.x

DD Version	Release Date	Compatible with model 705 PA	
		Firmware	Software Revision
Dev V1 DD V1	December 2007	3.0K	V2.11
Dev V2 DD V1	March 2009	3.1C	V2.11 (Rev 2)

1.4 Intrinsic Safety

The IEC61158 physical layer supports Intrinsic Safety (IS) applications with bus-powered devices. To accomplish this, an IS barrier or galvanic isolator is placed between the power supply in the safe area and the device in the hazardous area.

IEC61158 also supports the Fieldbus Intrinsically Safe Concept (FISCO) model which allows more field devices in a network. The FISCO model considers the capacitance and inductance of the wiring to be distributed along its entire length. Therefore, the stored energy during a fault will be less and more devices are permitted on a pair of wires. Instead of the conservative entity model, which only allows about 90 mA of current, the FISCO model allows a maximum of 110 mA for Class II C installations and 240 mA for Class II B installations.

FISCO certifying agencies have limited the maximum segment length to 1000 meters because the FISCO model does not rely on standardized ignition curves.

The Enhanced Eclipse Model 705 is available with entity IS, FISCO IS, FNICO non-incendive, or explosion proof approvals.

2.0 QuickStart Configuration

The Eclipse transmitter comes partially configured from the factory but can be reconfigured in the shop (disregard fault message due to unattached probe). The minimum configuration instructions required in the field follow.

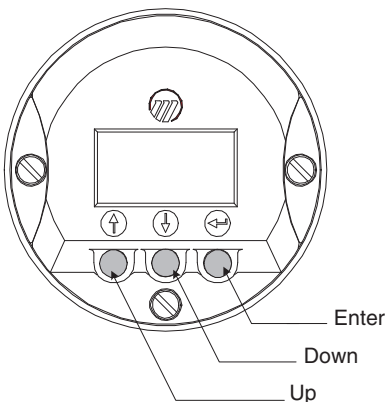

1. Power up the transmitter.
The display changes every 5 seconds to show one of two values: Status & Level.
2. Remove the cover of the lower electronic compartment.
3. Use the Up or Down Arrow (↑↓) keys to move from one step of the configuration program to the next step.
4. Press the Enter Arrow (↔) key. The last character in the first line of the display changes to an exclamation point (!). PrbModel
xxx
5. Use the Up or Down Arrow (↑↓) keys to increase or decrease the value in the display or to scroll through the choices.
6. Press the Enter Arrow (↔) key to accept a value and move to the next step of the configuration program (the default password is 0).
7. After entering the last value, allow 10 seconds before removing power from the transmitter.

The following configuration entries are the minimum required for configuration (the default password is 0 from the LCD/keypad).

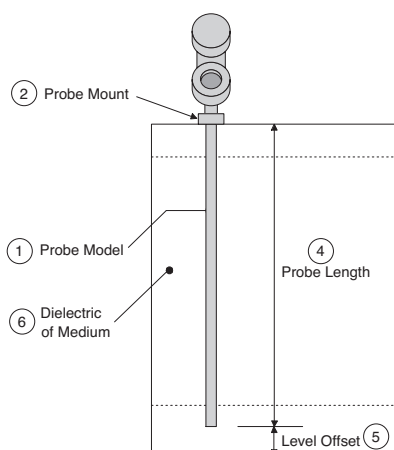

- | | | |
|---|-----------------------|--|
| ① | PrbModel
(select) | Select the Probe Model to be used
Model 705: 7xA-x, 7xB-x, 7xD-x, 7xE-x, 7xF-F, 7xF-P, 7xF-4, 7xF-x, 7xJ-x, 7xK-x, 7xP-x, 7xQ-x, 7xR-x, 7xS-x, 7xT-x, 7x1-x, 7x2-x, 7x5-x, 7x7-x |
| ② | PrbMount
(select) | Select the type of Probe Mounting to vessel (NPT, BSP, or flange). |
| ③ | MeasType
(select) | Select from Level Only, Level and Volume, Interface Level or Interface Level and Volume. |
| ④ | Probe Ln
xxx.x | Enter the exact Probe Length as printed on the probe nameplate. |
| ⑤ | LvlOfst
xxx.x | Enter the Level Offset value. Refer to Section 3.3.4 for further information. (The unit is shipped from the factory with offset = 0; i.e., all measurements are referenced to the bottom of the probe). |
| ⑥ | Dielectrc
(select) | Enter the Dielectric range for the material to be measured. |

3.0 Function Blocks

3.1 Overview

The Enhanced Eclipse Model 705PA is a Guided Wave Radar (GWR) level transmitter with six PROFIBUS PA™ Blocks (one Physical Block, one Transducer Block, and four Analog Input blocks). The idea of Function Blocks, which a user can customize for a particular application, is a key concept of fieldbus topology. Function Blocks consist of an algorithm, inputs and outputs, and a user-defined name.

The TRANSDUCER block output is available to the network through the ANALOG INPUT blocks.

The ANALOG INPUT blocks (AI) take the TRANSDUCER block level or volume values and makes them available as an analog value to the network. The AI blocks have scaling conversion, filtering, and alarm functions.

3.1.1 Standard PROFIBUS™ Block Parameters

The following are general descriptions of the parameters common to all blocks. Additional information for a given parameter is described later in that specific block section.

BLOCK_OBJECT: Contains the characteristics of the block. This object applies to every block and is placed before the first parameter.

ST_REV A read-only parameter to track changes of static parameters in the associated block. ST_REV will be incremented each time a static parameter is changed.

TAG_DESC (tag descriptor): A user-supplied description of the block.

STRATEGY: A user-specified value that may be used in configuration or diagnostics as a key in sorting block information.

ALERT_KEY: A user-assigned value that may be used in sorting alarms or events generated by a block.

TARGET_MODE: This attribute indicates what mode of operation is desired for the block.

MODE_BLK: A structured parameter composed of the actual mode, the normal and the permitted mode(s) of a block.

The actual mode is set by the block during its execution to reflect the mode used during execution.

The permitted mode shows which changes of the target mode are valid for the specific block.

ALARM_SUM: This parameter summarized the status of up to 16 block alarms.

3.2 Physical Block

The Physical Block contains data specific to the Enhanced Model 705 PA transmitter, along with some information about the firmware.

NOTE: The Physical Block has no control function.

MODE_BLK: Actual mode must be in AUTO in order for the AI Function blocks in the transmitter to operate.

NOTE: A Physical Block in “out of service” will stop all function block execution in the transmitter.

SOFTWARE_REVISION: Revision number of the software of the field device.

HARDWARE_REVISION: Revision number of the hardware of the field device.

DEVICE_MAN_ID: Identification code of the manufacturer of the field device.

DEVICE_ID: Manufacturer specific identification of the device.

DEVICE_SER_NUM: Serial number of the device.

DIAGNOSIS: Detailed information about the device, bitwise coded.

DIAGNOSIS_EXTENSION: Additional detailed information about the device.

DIAGNOSIS_MASK: Definition of supported DIAGNOSIS information-bits.

0 = not supported

1 = supported

DIAGNOSIS_MASK_EXTENSION: Definition of supported DIAGNOSIS_EXTENSION information-bits.

0 = not supported

1 = supported

DEVICE CERTIFICATION: Pertinent certifications of the device.

WRITE_LOCKING: Software write-protection can be enabled or disabled.

FACTORY_RESET: Command for resetting the device for default values. The setting of the bus address is not affected.

- **RESTART_WITH_DEFAULTS:** As RESTART DEFAULT will set all configuration parameters to their default values. Devices need to be reconfigured following activation of this function. The bus address is not affected.
- **WARM_START:** No parameters changed
- **RESET_ADDRESS_TO_DEFAULT:** Other parameter unchanged

DESCRIPTOR: User-definable text string to describe the device within the application.

DEVICE_MESSAGE: User-definable message string used to describe the device within the application of in the plant.

DEVICE_INSTAL_DATE: Installation date of the device.

IDENT_NUMBER_SELECTOR: Selects manufacturer-specific Ident number issued by PNO or profile-specific Ident number to determine features and behavior for interacting with device.

HW_WRITE_PROTECTION: Indicates the position of a write block mechanism (e.g., hardware jumper).

3.3 GWR Transducer Block

The GWR TRANSDUCER block is a custom block containing parameters that support the Enhanced Eclipse Model 705 level transmitter. It contains the GWR probe configuration, diagnostics, and calibration data, and outputs level with status information.

The TRANSDUCER block parameters are grouped in a useful configuration. There are both read-only parameters and read-write parameters within the TRANSDUCER block.

- The read-only parameters report the block status and operation modes.
- The read-write parameters affect the function block basic operation, level transmitter operation, and calibration.

The Transducer Block remains in AUTO mode even when the local interface (keypad) is used to change a parameter online.

3.3.1 GWR Transducer Block Parameters

The first eight parameters in the GWR TRANSDUCER block are the standard block parameters discussed in section 3.1.1. The standard parameters are followed by these additional required parameters for a Level Transducer Block: Corresponding parameter names from Profile specification are shown parenthetically if different from parameter names used by Model 705.

LEVEL (PRIMARY_VALUE): The process value Level is Probe Level + Level Offset and an associated status.

LEVEL_UNIT (PRIMARY_VALUE_UNIT): Unit of measurement for level process variable (primary value).

PROBE_LEVEL (LEVEL): Level on the probe relative to the end of the probe in Probe Level units.

PROBE_LEVEL_UNIT (LEVEL_UNIT): Unit of measurement for probe level parameters: Level Offset, Probe Level, Probe Level Hi, and Probe Level Lo.

SENSOR_VALUE: Sensor Value is the physical value of the sensor (distance).

SENSOR_UNIT: Unit of measurement for sensor parameters.

SENSOR_OFFSET: Distance from the sensor reference point to the top of the tank in sensor units.

CAL_TYPE: Defines type of calibration. Dry indicates that sensor value has no influence on the level calibration.

SENSOR_CAL_LO (CAL_POINT_LO): Sensor Cal Lo is the lower calibrated point of Sensor Value in sensor units. It refers to Probe Level Lo.

SENSOR_CAL_HI (CAL_POINT_HI): Sensor Cal Hi is the upper calibrated point of Sensor Value in sensor units. It refers to Probe Level Hi.

PROBE_LEVEL_LO (LEVEL_LO): Probe Level Low is the value of Probe Level at Sensor Cal Lo and is defined in Probe Level units.

PROBE_LEVEL_HI (LEVEL_HI): Probe Level Hi is the value of Probe Level at Sensor Cal Hi and is defined in Probe Level units.

LEVEL_OFFSET: Desired level reading when liquid surface is at end of probe. Level Offset is defined in Probe Level units.

LIN_TYPE: Type of linearization. No linearization is supported.

SENSOR_HIGH_LIMIT: Upper process limit of the sensor in sensor units.

SENSOR_LOW_LIMIT: Lower process limit of the sensor in sensor units.

Another important parameter found later in the **TRANSDUCER** block list is **DEVICE_STATUS**, which displays the status of the device. If more than one message exists, then the messages are displayed in priority order. Refer to Section 6.1.2, Error Messages.

If **DEVICE_STATUS** indicates a problem, refer to Section 6.1, Troubleshooting.

For a complete list of Transducer Block Parameters, refer to table in the Appendix.

3.3.2 Password Parameters

To change a parameter at the local user interface, a value matching the user password must be entered (Default=0). If the user password is entered, the instrument is in the user mode. After 5 minutes with no keypad activity, the entered password expires.

Factory password is for use by trained factory personnel only.

From the network, the instrument always behaves as if it is in the user mode by default. In other words, it is not necessary to enter the user password in order to write parameters from the network.

3.3.3 Eclipse Model 705 Configuration Parameters

This set of parameters within the Transducer Block is important and required to configure every Eclipse Model 705 transmitter.

PROBE_MODEL: Select the choice that corresponds to the first four digits of the model number of the probe. An “x” in the selection means that character is variable (the probe model number is shown on the nameplates attached to both the transmitter and probe). For example, 7xA-x should be chosen for probe models beginning with 7EA or 7MA.

PROBE_MOUNT: Select the type of mounting on the probe. The choices are NPT, BSP, and Flange.

MEASUREMENT_TYPE: Select from LEVEL ONLY, LEVEL AND VOLUME, INTERFACE, or INTERFACE AND VOLUME.

PROBE_LENGTH: Enter the exact length of the probe. The probe length is shown as the last three digits of the probe model number printed on the nameplates attached to the transmitter and probe. PROBE_LENGTH is shown in SENSOR_UNITS.

LEVEL_OFFSET: Enter the distance from the probe tip to the desired 0% reference in PROBE_LEVEL_UNITS. The acceptable range is from -300 inches to 600 inches. Refer to Section 3.3.4 for additional information.

DIELECTRIC_RANGE: Select from 10–100, 3–10, 1.7–3.0, or 1.7–1.4

NOTE: All dielectric ranges are not available with all probes.

If an unsupported dielectric range is selected, the transmitter will give a negative response and the value displayed will revert to its previous value.

THRESHOLD: The threshold can be set as either FIXED or CFD. The factory default is CFD. This parameter should only be changed to FIXED in those applications measuring total level having a lower dielectric material over a higher dielectric material. A typical example for FIXED Threshold is a hydrocarbon application having water bottoms.

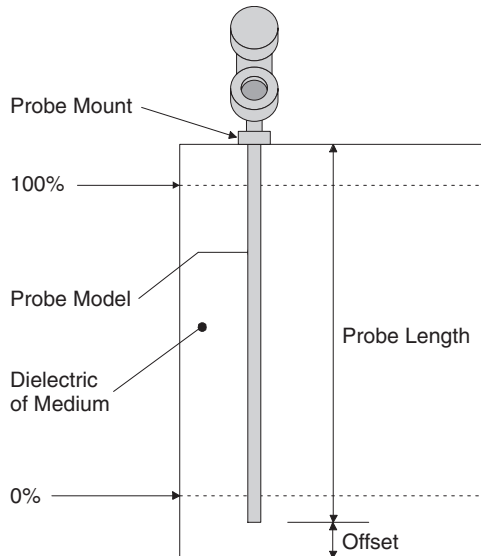

3.3.4 Offset Description

The parameter referred to as LEVEL_OFFSET in the Transducer Block is the desired level reading when liquid surface is at the end of the probe. The Eclipse transmitter is shipped from the factory with LEVEL_OFFSET set to 0. With this configuration, all measurements are referenced from the bottom of the probe. See Example 1.

Example 1 (LEVEL_OFFSET = 0 as shipped from factory):
Application calls for a 72-inch NPT Coaxial probe in water with the bottom of the probe 10 inches above the bottom of the tank. The user wants the 0% point at 24 inches and the 100% point at 60 inches as referenced from the bottom of the probe.

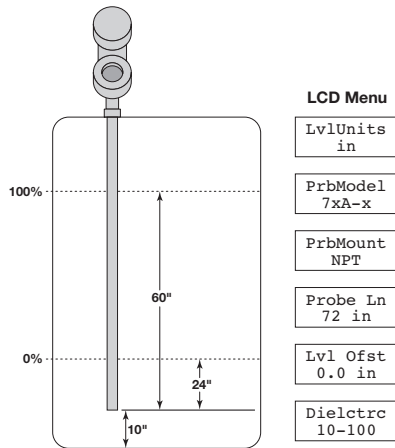

Example 1

In those applications in which it is desired to reference all measurements from the bottom of the vessel, the value of LEVEL_OFFSET should be changed to the distance between the bottom of the probe and the bottom of the vessel as shown in Example 2.

Example 2:

Application calls for a 72-inch NPT coaxial probe in water with the bottom of the probe 10 inches above the bottom of the tank. The user wants the 0% point at 24 inches and the 100% point at 60 inches as referenced from the bottom of the tank.

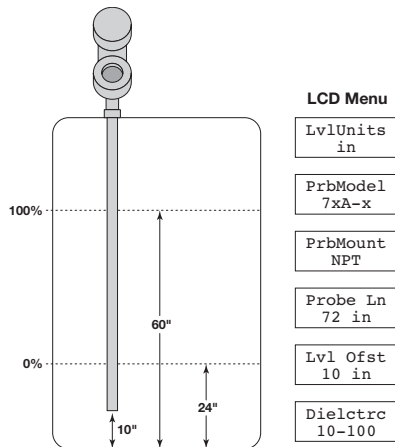

Example 2

When the Eclipse transmitter is mounted in a chamber/bridle, it is usually desirable to configure the unit with the 0% point at the lower process connection and the 100% point at the upper process connection. The span is the center-to-center dimension. In this case, a negative LEVEL_OFFSET needs to be entered. In doing so, all measurements are then referenced at a point up on the probe as shown in Example 3.

Example 3:

Application calls for a 48-inch cage-coaxial flanged probe measuring water in a chamber with the bottom of the probe 6 inches below the lower process connection. The user wants the 0% point to be 0 inches at the bottom process connection and the 100% point to be 30 inches at the top process connection.

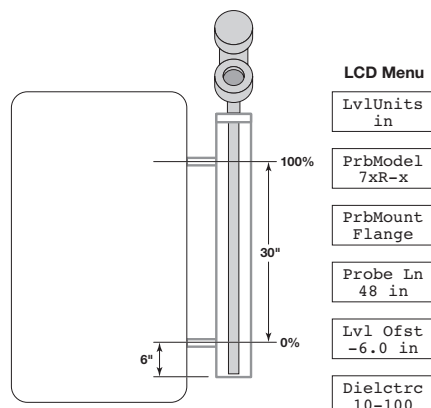

Example 3

3.4 User-Calibration Parameters

One of the main advantages of the Enhanced Eclipse Model 705 transmitter is that the device does not need to be calibrated in the field. Every Enhanced Eclipse Model 705 transmitter is shipped from the factory precisely calibrated.

Part of the advantage of PROFIBUS PA™ is to provide the ability to monitor changes and make adjustments to a transmitter. The fieldbus concept allows a user to make calibration adjustments if deemed necessary.

NOTE: The original factory calibration settings are restored when a new probe length value is assigned.

It is highly recommended that factory calibration be used for optimum performance.

Contact the factory for information on how to perform a User Calibration.

3.4.1 Factory Parameters

The following parameters are used for either troubleshooting or are parameters adjusted at the factory. They should never be changed in the field.

The factory-adjustable calibrated parameters are WINDOW, CONVERSION_FACTOR, and SCALE_OFFSET.

WINDOW is used to adjust for the variations in the analog section of the Eclipse TDR measurement engine. CONVERSION_FACTOR and SCALE_OFFSET are the main factory calibration settings.

WINDOW: determines the amount of delay between the generation of the transmitted signal pulse and the start of the measurement cycle.

FID_TICKS: a measure of the time to the fiducial (reference) pulse.

LEVEL_TICKS: a measure of the time to the level of the product being measured.

CONVERSION_FACTOR: the slope of the factory-set calibration line.

SCALE_OFFSET: the intercept of the calibration line.

3.4.2 Firmware Version

The last parameter in the TRANSDUCER block gives the firmware version of the transmitter.

FIRMWARE_VERSION: displays the version of the firmware.

3.5 Analog Input Block

The ANALOG INPUT (AI) block takes the Transducer Block input data, selected by channel number, and makes it available to other function blocks at its output:

1. Level
2. Volume
3. Interface
4. Interface Volume

3.5.1 AI Block Parameters

The first eight parameters in an AI block are the standard block parameters discussed in section 3.1.1. Additional analog input function block parameters are as follows:

BATCH: A parameter intended to be used in Batch application in line with IEC 61512 Part 1.

OUT: Contains the current measurement value in the configuration engineering unit.

PV_SCALE: High and low scale values used to convert Process Variable Configured by channel into percent.

OUT_SCALE: The high and low scale values, the engineering code, and number of digits to the right of the decimal point to be used in displaying the OUT parameters.

LIN_TYPE: Type of linearization. No linearization is supported in the AI function blocks.

CHANNEL: Selects the measurement value from an active transducer block as the input to the function block.

PV_FTIME: Filter time of the Process Variable.

FSAFE_TYPE: Defines the reaction of a device, if a fault is detected and the quality of the process variable input from the transducer block is BAD.

0 = FSAFE_VALUE is used as OUT

1 = Use last stored valid OUT value

2 = OUT has incorrect calculated value; status remains "bad".

FSAFE_VALUE: Default value for the OUT parameter, if a fault is detected, and FSAFE_TYPE is 0.

HI_LIM: Value of the upper limit of warnings.

LO_LIM: Value of the lower limit of warnings.

ALARM_HYS: Hysteresis to adjust sensitivity of alarm triggering.

HI_HI_LIM: Value of the upper limit of alarms.

HI_LIM: Value of the upper limit of warnings.

LO_LIM: Value of the lower limit of warnings.

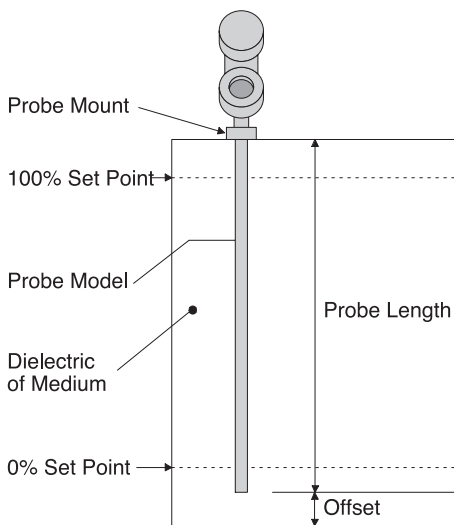

Scaling

LO_LO_LIM: Value of the lower limit of alarms.

HI_HI_ALM: State of the upper limit of alarms.

HI_ALM: State of the upper limit of warnings.

LO_ALM: State of the lower limit of warnings.

LO_LO_ALM: State of the lower limit of alarms.

SIMULATE: For commissioning and test purposes, the input value of the Transducer Block in the AI Block can be modified.

OUT_UNIT_TEXT: Allows the user to write text if a specific unit of the OUT parameter is not in the code list.

The TRANSDUCER and AI Block's actual mode in the MODE_BLK parameter must be set to AUTO to pass the PV Value through the AI to the network.

Transducer scaling, called PV_SCALE, is applied to the PV from the CHANNEL to produce the FIELD_VAL in percent. Units of PV_SCALE are the same as the units of the TRANSDUCER BLOCK process variable configured by channel.

Damping Filter is a feature of the AI Block. PV_FTIME parameter is the time constant of a single exponential filter for the PV, in seconds. This parameter can be used to dampen out fluctuation in level due to excessive turbulence.

The AI Block has multiple ALARM functions that monitor the OUT parameter for out of bound conditions.

3.5.2 Local Display of Analog Input Block Output Values

The Model 705 3x PROFIBUS PA™ [Device Revision 2] transmitter incorporates a feature that allows the device's Analog Input [AI] Block Out values to be displayed on the local LCD.

NOTE: There are many reasons that AI Block Out values can deviate from the measurement value originating in the Transducer block, and because the keypad and local display will only provide access to Transducer block parameters, there is no way to explore or change the other fieldbus configuration items affecting the AI Block output using the keypad and LCD.

These screens should only be considered as measured value indicators for configured transmitters.

- The screens are not used for commissioning or diagnostic / troubleshooting purposes.
- Prior to configuration of AI Blocks, the value displayed will not reflect the transducer measurement. (Pre-configuration values will typically be 0).

3.5.2.1 AI Out Display Screens

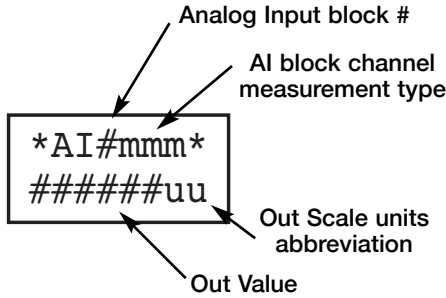

Analog Input Out Display

The Analog Input Out values will be conditionally displayed as part of the “rotating” home menu screens.

The screens will be formatted as shown where # in the title is the number of the AI block (1, 2, 3, or 4) and mmm is one of: “Lvl”, “Vol”, “Ifc”, “IfV”, “---” depending on the value of the associated AI block’s Channel parameter.

- For example, “AI1Lvl” would be the most commonly used AI Out screen.
- “AI2---” would be displayed when the channel value is 0 [uninitialized] for AI block 2.

The Out value will be displayed subject to limitations necessary for a 6-character display [999999 > Value > -99999].

Representative examples are shown below:

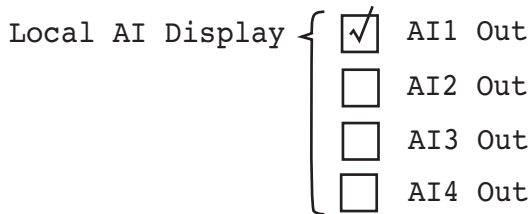
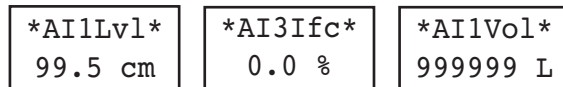

Because the Model 705 transmitter has four Analog Input blocks any or all of which may be used in particular applications, a Transducer block parameter controls which AI block Out values will be displayed.

The fieldbus presentation of this parameter will be similar to that shown at left (host system dependent).

Any or all (or none) of the AI block Out values can be selected for display on the LCD.

The local LCD version of this parameter is shown differently due to the limitations of the LCD:

LCD label: “**AI Disp**”

The default value of the Local AI Display parameter will be such that AI 1 Out is selected.

None	AI4
AI1	AI1+AI4
AI2	AI2+AI4
AI1+AI2	AI1,2,4
AI3	AI3+AI4
AI1+AI3	AI1,3,4
AI2+AI3	AI2,3,4
AI1,2,3	All AIs

Analog Input Out Values To Be Displayed

4.0 Model 705 Menu: Step by Step Procedures

The following table describes the software menu displayed by the Eclipse PROFIBUS PA™ transmitter for “Level Only” measurement. Use this table as a step by step guide to configure the transmitter.

The second column presents the menus shown on the transmitter display. The displays are in the order they would appear if the arrow keys were used to scroll through the menu. The numbers on the first column are not shown in the display. They are only provided as reference.

The third column provides the actions to take when configuring the transmitter. Additional information or an explanation of an action is given in the fourth column. (Shaded sections are factory menu items).

	Display	Password	Action	Comment
1	*Status* *Level* *AllLvl*	None	Transmitter Display	MeasType = Lvl Only
2	Level xxx.x lu	None	Transmitter Display	All MeasType selections
3	LvlUnits (select)	User	Select the Level units	Select from cm, inches, feet, meters, percent
4	AllLvl xx.x%	None	Transmitter Display	All MeasType selections
5	PrbModel (select)	User	Select the type of probe used	Select from 7xA-x, 7xB-x, 7xD-x, 7xG-x, 7xK-x, 7xP-x, 7xQ-x, 7xR-x, 7xE-x, 7xF-x, 7xF-E, 7xF-F, 7x1-x, 7x2-x, 7x5-x, 7x7-x, 7xF-4, 7xF-P, 7xJ-x, 7xL-x, 7xM-x, 7xN-x, 7xS-x, 7xT-x
6	PrbMount (select)	User	Select the type of probe mounting	Select from NPT, BSP or Flange
7	MeasType (select)	User	Select type of measurement	Select from Lvl Only, Lvl&Vol, Intrface, lfc&Vol
8	SnsrUnit (select)	User	Select the Sensor units	Select from cm, inches, feet, meters
9	Probe Ln xxx.x su	User	Enter the exact length of the probe	11.8 to 900 in (30 to 2286 cm)
10	PrbLvlUn	User	Select Probe Level units	Select from cm, inches, feet, meters, percent
11	Lvl Ofst xxx.x plu	User	Enter desired Level reading when probe is dry	-90 to 300 in (-228.6 to 762 cm)
12	Dielctrc (select)	User	Select range bounding the dielectric constant of the medium	Select from 1.4-1.7, 1.7-3, 3-10, 10-100
13	Senstvty xxx	Superuser or user	Adjust gain value upward or downward to sense liquid surface	(Superuser password required for dual element probes.)
14	BlockDis xx.x su	User	Enter distance below reference point where level is not sensed	-99.9 to 2286 cm (-39.3 to 900 in)
15	SftyZone (select)	User	Select behavior when level is sensed in safety zone	Off, On, Latch

	Display	Password	Action	Comment
16	SZHeight xx.x su	User	Enter distance below BlockDis where SZ Fault will be asserted	5.1 to 2286 cm (2 to 900 in)
17	SZ Latch Reset	User	Press Enter to clear a Safety Zone latch	
18	Threshld (select)	User	Select from CFD, Fixed	For interface, refers to threshold for upper level pulse
19	Trim Lvl xx.x su	Superuser or user	Enter value to adjust Level reading	-20.0 inches <= Lvl Trim <= +20.0 inches (Superuser password required if negative fiducial.)
20	Dev Addr	User	Set Device Address	0 to 126
21	AIDisp (select)	User	Select AI Block Out values to be displayed	
22	LvlTicks xxxxx	User	Diagnostic Display	Time of flight from fiducial to level signal
23	New Pass xxx	User	Enter new password (0-255)	Displays encrypted value of present password
24	Language (select)	User	Select from English, Spanish, French, German	Language choice for LCD display
25	Mdl705PA Ver 3.0A	None	Transmitter Display	Product identification Firmware version
26	DispFact (select)	None	Select Yes to display factory parameter menus	
27	History Status (status)	None	Diagnostic Display to view present status and recent exceptions	
28	Run Time xxxx.x h	None	Diagnostic Display showing elapsed time since power on	Cleared to zero with History Reset
29	History Reset	Superuser	Press Enter and select yes to clear history	Similar to SZ Mode Reset.
30	HF Cable (select)	Superuser	Select length of remote extension cable	Select Integral, 3-foot, 12-foot
31	FidTicks xxxx	None	Diagnostic Display	Time of flight from start of ramp to fiducial
32	Fid Sprd xxx	None	Diagnostic Display	Spread in fiducial ticks readings
33	Fid Type (select)	Superuser	Superuser parameter	Select from Positive, Negative. Selection only allowed for some probes, fixed for others
34	Fid Gain xxx	Superuser	Superuser parameter	
35	Window xxx	Factory	Factory Parameter	Calibration parameter
36	Conv Fct xxxx	Factory	Factory Parameter	Calibration parameter
37	Scl Ofst xxx	Factory	Factory Parameter	Calibration parameter
38	Neg Ampl xxx	Superuser	Superuser Parameter	Diagnostic parameter
39	Pos Ampl xxx	Superuser	Superuser Parameter	Diagnostic parameter
40	Signal xxx	None	Diagnostic Display	Indication of level signal amplitude

	Display	Password	Action	Comment
41	Compsate	Superuser	Superuser Parameter	Select from None, Manual, Auto
42	DrateFct xxxx	None	Diagnostic Display	Compsate = Auto, velocity derating factor
43	TargAmpl xxxx	None	Diagnostic Display	Compsate = Auto, target negative threshold amplitude
44	Targ Tks xxxx	None	Diagnostic Display	Compsate = Auto, measured time of flight from fiducial to target
45	Targ Cal xxxx	Superuser	Diagnostic Display	Compsate = Auto, calibrated time of flight from fiducial to target in room temperature air
46	OperMode (select)	Superuser	Superuser Parameter	Compsate = Auto, select from Run, Cal, Off
47	7xK Corr xxx	Superuser	Superuser Parameter	Probe Model = 7xK, Distance in mm from fiducial to user reference point
48	Snsr Val xxx.x su	None	Distance to the target relative to the sensor reference point.	
49	SnrCalLo xxx.x su	Superuser	The lower calibrated point of Sensor Value. It refers to PrLvl Lo.	In Sensor Units. Set to entered Probe Ln
50	SnrCalHi xxx.x su	Superuser	The higher calibrated point of Sensor Value. It refers to PrLvl Hi.	In Sensor Units
51	ProbeLvl xxx.x plu	None	Level on the probe relative to the end of the probe.	
52	PrLvl Lo xxx.x plu	Superuser	Value of PrLvl at SnrCalLo.	In Probe Level Units
53	PrLvl Hi xxx.x plu	Superuser	Value of PrLvl at SnrCalHi.	In Probe Level Units
54	ElecTemp xxx C	None	Diagnostic Display	Present temperature in electronics compartment (degrees Celsius)
55	Max Temp xxx C	Superuser	Diagnostic Display	Maximum electronics temperature recorded
56	Min Temp xxx C	Superuser	Diagnostic Display	Minimum electronics temperature recorded
57	SZ Hyst xx.x su	Superuser	Superuser Parameter	Safety Zone hysteresis height

5.0 Diagnostic Parameters

The Eclipse Model 705 measurement engine runs through a series of self-tests and will detect and report faulty operation. The TRANSDUCER BLOCK displays these faults in the DEVICE_STATUS parameter. Refer to Section 6.1.2 for more information on specific faults and warnings.

When the Model 705 transmitter is initially powered on, the measurement engine does not have enough valid measurement cycles to make a decision about the output level. For the first sixteen measurement cycles after power is applied, the QUALITY is “Uncertain,” the SUB_STATUS is “Initial value,” and the LIMIT attribute is “Constant.”

When the Model 705 is operating correctly, the QUALITY is shown as “GOOD,” and the SUB_STATUS is “Non-Specific.”

Depending on the FAIL SAFE MODE in AI BLOCK, when the Enhanced Model 705 measurement cycle fails to find a valid output level, the transmitter maintains the last good value as the output and flags the failure. The LIMIT attribute is the same as the last good measurement. Excessive disrupted cycles causes the transmitter to go into a defined operational mode based on the cause of the disrupted cycles.

When the Enhanced Model 705 detects a level above the highest measurement point of the probe the operational mode is shown as “May Be Flooded.” This is due to the fact that since the actual level location above the top of some probes is not known, the output may not be accurate.

The Model 705 operational mode is DRY_PROBE when the level is below the end of the probe. Again, the output may not be accurate, since the location of the level below the end of the probe is not known. The TRANSDUCER BLOCK output is calculated as LEVEL_OFFSET.

When in the dry probe condition, the Model 705 compares the measured length of the probe to the value entered into the PROBE_LENGTH parameter. If the measured value does not match PROBE_LENGTH, a fault is reported. The QUALITY will be shown as “Bad,” and the SUB_STATUS is “Configuration error.”

If the Model 705 fails to find a measurable level, either due to an actual loss of a level signal or the loss of a proper Fiducial (reference) signal, the TRANSDUCER BLOCK maintains the last good value as the output and flags the failure. The QUALITY is “Bad,” the SUB_STATUS is “Sensor failure” for no level (or “Device failure” for loss of the Fiducial), and the LIMIT attribute is “Constant.”

Device status conditions and the effects on PV Status are summarized in section 6.1.2.

5.1 Simulation Feature

The Eclipse Model 705 with PROFIBUS PA™ supports the Simulate feature in the Analog Input Block. The Simulate feature is typically used to exercise the operation of an AI block by simulating a TRANSDUCER block input.

When an Analog Input Block is in Manual Mode, the operator can also set the value and status of the OUT parameter to simulate different AI BLOCK outputs.

6.0 Reference Information

6.1 Troubleshooting

WARNING!

Explosion hazard. Do not connect or disconnect equipment unless power has been switched off or the area is known to be non-hazardous.

The Eclipse transmitter is designed and engineered for trouble-free operation over a wide range of operating conditions. Common transmitter problems are discussed in terms of their symptoms and recommended corrective actions. Information on how to handle material buildup on the probe is also provided in this section.

6.1.1 Troubleshooting System Problems

Symptom	Problem	Solution
LEVEL and % OUTPUT values are inaccurate.	Basic configuration data is questionable.	Reconfigure the Probe Model and/or Probe Mount, Probe Length or Level Offset. 1) Ensure the Level is accurate.
	Interface level has significant emulsion.	Examine process to reduce/eliminate emulsion layer.
LEVEL readings are repeatable but consistently high or low from actual by a fixed amount.	Configuration data does not accurately match probe length or tank height.	Ensure proper Probe Model, Level Offset & probe length. Adjust trim level value by the amount of noted inaccuracy.
LEVEL and % OUTPUT values fluctuate.	Turbulence	Increase the Damping factor until the readings stabilize.
	High Frequency connection	Check Fid Spread (should be stable within ± 10 counts).
LEVEL and % OUTPUT values all reading low vs. actual.	Lower dielectric material over higher dielectric material, e.g., oil over water	Select Fixed Threshold option.
	Coating, clumping or buildup on probe	These may be expected inaccuracies due to affect on pulse propagation.
	Dense, water based foam	These may be expected inaccuracies due to affect on pulse propagation.
Level Reading on Display is stuck at full scale.	Software believes probe is flooded (level near very top of probe).	Check actual level. If probe is not flooded, Check for buildup or obstructions near top of probe. Select higher dielectric range. Check for condensation in probe connection. Add Blocking Distance.
LEVEL and % OUTPUT values values all at maximum level.	Possible configuration issue with single rod probe	1) Increase Blocking Distance 2) Increase Dielectric Range
LEVEL and % OUTPUT values reading high vs. actual.	Possible obstruction in tank affecting single rod probe	1) Increase Dielectric Range until obstruction is ignored 2) Relocate probe away from obstruction
LEVEL value reading high when should be zero.	Transmitter loose or disconnected from probe	Ensure transmitter connected securely to probe.

NOTE: When consulting the factory concerning improper operation, use proper tables on pages 28-29. Enter all data when transmitter is working CORRECTLY and INCORRECTLY.

6.1.2 Device Status Parameter in the Transducer Block

The following table lists the conditions indicated in the Device Status parameter. It also shows the affect the condition has on PV status, Sub-Status and Limit.

Device Status				PV Status	PV Sub Status	Limit
Type	Label	Bit #	Value	Quality		
Mode	OK	15	0x00008000	Good	Non-Specific	Not Limited
Fault	Default Params	28	0x10000000	Bad	Configuration Error	Not Limited
Fault	No End of Ramp	27	0x08000000	Bad	Device Failure	Constant Limited
Fault	Lvl<Probe Length	23	0x00800000	Bad	Sensor Failure	Constant Limited
Fault	No Fiducial	21	0x00200000	Bad	Device Failure	Constant Limited
Fault	Safety Zone FLT	20	0x00100000	Bad	Non-Specific	Not Limited
Fault	No Signal	19	0x00080000	Bad	Sensor Failure	Constant Limited
Fault	EOP<Probe Length	18	0x00040000	Bad	Sensor Failure	Constant Limited
Fault	EOP High	17	0x00020000	Bad	Configuration Error	Not Limited
Fault	High Volume Fit	16	0x00010000	Bad	Configuration Error	High Limited
Warning	Hi Temperature	11	0x00000800	No Effect	No Effect	No Effect
Warning	Lo Temperature	10	0x00000400	No Effect	No Effect	No Effect
Warning	Default Cal	9	0x00000200	No Effect	No Effect	No Effect
Warning	Initializing	4	0x00000010	Uncertain	Initial Value	Constant Limited
Warning	May be Flooded	3	0x00000008	No Effect	No Effect	High Limited
Warning	Dry Probe	2	0x00000004	No Effect	No Effect	Low Limited
Warning	Weak Signal	1	0x00000002	No Effect	No Effect	No Effect
Warning	No Steam Target	6	0x00000040	No Effect	No Effect	No Effect

The first condition is Type Mode. If everything is running normally and there are no Faults or Warnings, then the device indicates it is “OK” an the local display and in Device Status.

The next set of conditions is device faults. The device will most likely not be able to measure level correctly if one or more of these conditions occur. The condition will be indicated in Device Status and will affect PV Status, Sub-Status and Limit as indicated.

The next set of conditions is the device warnings. The condition will not jeopardize the level measurement. However, knowledge of the condition may be useful in troubleshooting the device.

The following table describes the conditions that can be seen in Device Status:

Display Message	Action	Comment
OK	None	Normal operating mode.
Default Params	Internal non-volatile parameters have been defaulted.	Consult factory.
No End of Ramp	No End-of Ramp signal detected.	Consult factory.
No Fiducial	Fiducial signal is not being detected.	1) Check connection between probe and transmitter. 2) Check for moisture on top of probe. 3) Check for damaged gold pin in the high frequency connector. 4) Consult factory.

6.1.2 Device Status Parameter in the Transducer Block (cont.)

Display Message	Action	Comment
Safety Zone Flt	Safety Zone Alarm has been tripped.	Decrease level in vessel.
No Signal	No level signal being detected.	1) Ensure Dielectric setting is correct for the measured medium. 2) Increase Sensitivity 3) Confirm Probe Model is proper for the dielectric of the medium. 4) Consult factory.
EOP<Probe Length	End of Probe signal from a dry probe is out of range.	1) Ensure the Probe Length is entered correctly. 2) Set Dielectric to a lower dielectric range. 3) Consult factory. 4) Ensure proper Blocking Distance.
Lvl<Probe Length	Apparent position of the upper level pulse is beyond the end of the probe.	1) Check entered Probe Length. 2) Change Threshold to Fixed.
EOP High	End of Probe signal is out of range.	1) Ensure Probe Length is entered correctly. 2) Consult factory.
High Volume Flt	Level more than 5% above highest point in strapping table.	1) Verify strapping table is entered correctly. 2) Signal amplitude may be lower than desired.
Hi Temperature	Present temperature in electronics compartment is above 80 C.	1) Transmitter may need to be moved to ensure ambient temperature is within specification. 2) Change to remote mount transmitter.
Lo Temperature	Present temperature in electronics compartment is below -40° F (-40° C).	1) Transmitter may need to be moved to ensure ambient temperature is within specification. 2) Change to remote transmitter.
Default Cal	Factory set default calibration parameters are in use. Level reading may be inaccurate.	Consult factory.
No Steam Target	No steam target detected on Model 7x5 probe.	Consult factory.
Initializing	None	Program is initializing. This is a transient condition.
May be Flooded	Loss of level signal possibly due to flooding. Twin Rod probes only.	1) Decrease level in vessel. 2) Set Dielectric to lower range value. 3) Replace with Model 7xR Overfill probe.
Dry Probe	None	Normal message for a dry probe. End of Probe signal is being detected in correct location.
Weak Signal	None. Signal amplitude is lower than desired.	1) Set Dielectric to a lower range value. 2) Increase Sensitivity.

6.1.3 Error Mapped to Diagnosis

Some error codes are mapped to information bits in the PHYSICAL_BLOCK_DIAGNOSIS parameter as shown in the following table:

Display Message	Description
No Signal Fault	Failure in Measurement
Lvl<PL Fault	Failure in Measurement
EOP<PL Fault	Failure in Measurement
No End of Ramp Fault	Electronic Hardware Failure/Maint Required
No Fiducial Fault	Electronic Hardware Failure/Maint Required
Default Parameters Fault	Configuration not valid
EOP High Fault	Configuration not valid
Hi Temperature Warning	Electronic Temperature too high

6.1.3 Error Mapped to Diagnosis (cont.)

Note that PV status for Interface and Volume process variables may indicate a configuration error if the correct Measurement Type has not been selected. In this case, “Configuration not valid” will not be set in the DIAGNOSIS parameter since level measurement may still be correct.

Also, a Default Parameters Fault is indicated after a Factory Reset which will result in the DIAGNOSIS indication “Configuration not valid”.

6.1.4 PROFIBUS PA™ Segment Checklist

There can be several reasons for a PROFIBUS PA™ installation to be in a faulty condition. In order to assure that communication can be established, the following requirements must be met.

- Device supply voltage must be higher than 9 VDC with a maximum of 32 VDC.
- Total current draw of a given segment cannot exceed the rating shown on the power conditioner and/or barrier.
- Device polarity must be correct.
- Two 100 Ω, 1 μF terminators must be connected to the network—one at each end of the segment.
- Cable length plus spur length must not exceed the following

Number of Spurs	1 Device	2 Devices	3 Devices	4 Devices
25–32	—	—	—	—
19–24	100 ft. (30 m)	—	—	—
15–18	200 ft. (60 m)	100 ft. (30 m)	—	—
13–14	300 ft. (90 m)	200 ft. (60 m)	100 ft. (30 m)	—
1–12	400 ft. (120 m)	300 ft. (90 m)	200 ft. (60 m)	100 ft. (30 m)

Pair	Shield	Twisted	Size	Length	Type
Single	Yes	Yes	AWG 18 (0.8 mm ²)	6,200 ft. (1,900 m)	A
Multi	Yes	Yes	AWG 22 (0.32 mm ²)	3,900 ft. (1,200 m)	B
Multi	No	Yes	AWG 26 (0.13 mm ²)	1,300 ft. (400 m)	C
Multi	Yes	No	AWG 16 (1.25 mm ²)	650 ft. (200 m)	D

values:

- The cable shield is to be hard grounded only at one point close to the DCS. In addition, the cable shield can be capacitively grounded in multiple places to improve EMC protection.

If all of these requirements are met, a stable communication should be established.

6.2 References

1. “PROFIBUS™, A Pocket Guide” by Ronald W. Mitchell
2. PNO Specification 3.042, “Profile for Process Control Devices”
3. PNO Specification 2.092, “PROFIBUS PA - User and Installation Guideline”

Appendix – Transducer Block Parameters

INDEX	PARAMETER NAME	PARAMETER LABEL
0	BLOCK_OBJECT	BLOCK OBJECT
1	ST_REV	ST REV
2	TAG_DESC	TAG DESC
3	STRATEGY	STRATEGY
4	ALERT_KEY	ALERT KEY
5	TARGET_MODE	TARGET MODE
6	MODE_BLK (Act, Perm, Norm)	MODE BLK
7	ALARM_SUM	ALARM SUM
8	LEVEL	Level
9	LEVEL_UNIT	Level Unit
10	PROBE_LEVEL	Probe Level
11	PROBE_LEVEL_UNIT	Probe Level Unit
12	SENSOR_VALUE	Sensor Value
13	SENSOR_UNIT	Sensor Unit
18	SENSOR_OFFSET	Sensor Offset
19	CAL_TYPE	Calibration Type
20	CAL_POINT_LO	Sensor Cal Lo
21	CAL_POINT_HI	Sensor Cal Hi
22	PROBE_LEVEL_LO	Probe Level Lo
23	PROBE_LEVEL_HI	Probe Level Hi
24	LEVEL_OFFSET	Level Offset
25	LIN_TYPE	Lin Type
28	SENSOR_HIGH_LIMIT	Sensor High Limit
29	SENSOR_LOW_LIMIT	Sensor Low Limit
53	PROBE_MODEL	Probe Model
54	PROBE_MOUNT	Probe Mount
55	MEASUREMENT_TYPE	Measurement Type
56	PROBE_LENGTH	Probe Length
57	DIELECTRIC_RANGE	Dielectric Range
58	SENSITIVITY	Sensitivity
59	BLOCKING_DISTANCE	Blocking Distance
60	SAFETY_ZONE_MODE	Safety Zone Mode
61	SAFETY_ZONE_HEIGHT	SZ Height
62	SZ_LATCH_RESET	SZ Latch Reset
63	THRESHOLD	Threshold
64	TRIM_LEVEL	Trim Level
65	VOLUME	Volume
66	VOLUME_UNIT	Volume Unit
67	INTERFACE	lfc Level
68	INTERFACE_UNIT	lfc Level Unit
69	UPPER_LIQUID_DIELECT	Upper Dielectric
70	INTERFACE_THRESHOLD	Interface Threshold
71	INTERFACE_VOLUME	lfc Volume
72	INTERFACE_VOL_UNIT	lfc Volume Unit
73	STRAP_TABLE_LENGTH	Strapping Table Length
74	TABLE_VOLUME_UNIT	Table Volume Unit
75	STRAPPING_TABLE_PT01	StrappingTbl Pt01
76	STRAPPING_TABLE_PT02	StrappingTbl Pt02
77	STRAPPING_TABLE_PT03	StrappingTbl Pt03
78	STRAPPING_TABLE_PT04	StrappingTbl Pt04
79	STRAPPING_TABLE_PT05	StrappingTbl Pt05
80	STRAPPING_TABLE_PT06	StrappingTbl Pt06
81	STRAPPING_TABLE_PT07	StrappingTbl Pt07
82	STRAPPING_TABLE_PT08	StrappingTbl Pt08
83	STRAPPING_TABLE_PT09	StrappingTbl Pt09
84	STRAPPING_TABLE_PT10	StrappingTbl Pt10
85	STRAPPING_TABLE_PT11	StrappingTbl Pt11

INDEX	PARAMETER NAME	PARAMETER LABEL
86	STRAPPING_TABLE_PT12	StrappingTbl Pt12
87	STRAPPING_TABLE_PT13	StrappingTbl Pt13
88	STRAPPING_TABLE_PT14	StrappingTbl Pt14
89	STRAPPING_TABLE_PT15	StrappingTbl Pt15
90	STRAPPING_TABLE_PT16	StrappingTbl Pt16
91	STRAPPING_TABLE_PT17	StrappingTbl Pt17
92	STRAPPING_TABLE_PT18	StrappingTbl Pt18
93	STRAPPING_TABLE_PT19	StrappingTbl Pt19
94	STRAPPING_TABLE_PT20	StrappingTbl Pt20
95	FID_TICKS	Fiducial Ticks
96	FID_SPREAD	Fiducial Spread
97	LEVEL_TICKS	Level Ticks
98	INTERFACE_TICKS	Interface Ticks
99	INTERFACE_MEDIUM	Interface Medium
100	ENTER_PASSWORD	Enter Password
101	NEW_PASSWORD	New User Password
102	DEVICE_STATUS	Device Status
103	HISTORY_MESSAGE	History Message
104	HISTORY_CONTROL	History Control
105	RESET_HISTORY	Reset History
106	FID_TYPE	Fiducial Type
107	FID_GAIN	Fiducial Gain
108	WINDOW_705	Window
109	CONVERSION_FACTOR	Conversion Factor
110	SCALE_OFFSET	Scale Offset
111	NEGATIVE_AMPLITUDE	NegThreshold Ampl
112	INTERFACE_AMPLITUDE	lfcThreshold Ampl
113	POSITIVE_AMPLITUDE	PosThreshold Ampl
114	SIGNAL	Signal Strength
115	COMPENSATION	Compensation Mode
116	DERATE_FACTOR	Derating Factor
117	TARGET_AMPLITUDE	Target Amplitude
118	TARGET_TICKS	Target Ticks
119	TARGET_CAL	Targ Calib Value
120	TARGET_OPER_MODE	Target OperMode
121	SEVENXK_DIST_CORRECT	7XK Correction
122	ELECT_TEMPERATURE	Elec Temperature
123	MAX_ELECTRONICS_TEMP	Max Temperature
124	MIN_ELECTRONICS_TEMP	Min Temperature
125	RESET_ELECT_TEMP	Reset Temperature
126	SZ_HYSTERESIS	SZ Hysteresis
127	LCD_LANGUAGE	LCD Language
128	STEAM_CAL_MOUNT	Steam Cal Mount
129	RAMP_SLOPE	Ramp Slope
130	BASE_FID_TICKS	Base Fid Ticks
131	FACTORY_PARAM_1	Factory Param 1
132	FACTORY_PARAM_2	Factory Param 2
133	ECHO_SUMMARY	Echo Summary
134	ECHO_DATA	Echo Data
135	ECHO_DATA_INDEX	EchoData Indx
136	NON_VOL_STAT	Non Vol Stat
137	DATE_CODE	Date Code
138	MAGNETROL_SERIAL_NUM	Magnetrol S/N
139	FIRMWARE_VERSION	Firmware Version
140	LOCAL_AI_DISPLAY	Local AI Display
141	HF_CABLE	HF Cable
142	NSP_VALUE	NSP Value

Enhanced Model 705 Eclipse Guided Wave Radar Transmitter PROFIBUS PA™ Configuration Data Sheet

Copy blank page and store calibration data for future reference and troubleshooting.

Item	Value	Value	Value		
Vessel Name					
Vessel #					
Process Medium					
Tag #					
Electronics Serial #				TROUBLESHOOTING	
Probe Serial #				Working Value	Non-Working Value
LvlUnits					
VolUnits (opt.)					
IfcUnits (opt.)					
IfcVolUn (opt.)					
PrbModel					
PrbMount					
MeasType					
SnsrUnit					
Probe Ln					
PrbLvlUn					
Lvl Ofst					
TblVolUn (opt.)					
StrapTbl (opt.)					
Upr Diel (opt.)					
Dielctrc					
Sensvty					
BlockDis					
SftyZone					
SZHeight					
Threshld					
IfcThrsh (opt.)					
Trim Lvl					
AI Disp					
Dev Addr					
Language					
HF Cable					
Fid Type					
Fid Gain					
Window					
Conv Fct					
Scl Ofst					

Enhanced Model 705 Eclipse Guided Wave Radar Transmitter PROFIBUS PA™ Configuration Data Sheet

Copy blank page and store calibration data for future reference and troubleshooting.

Item	Value	Value	Value	TROUBLESHOOTING	
				Correct Value	Incorrect Value
Neg Ampl					
Ifc Ampl (opt.)					
Pos Ampl					
Compsate					
Targ Cal (opt.)					
OperMode (opt.)					
7xK Corr (opt.)					
SnrCalLo					
SnrCalHi					
PrLvl Lo					
PrLvl Hi					
SZ Hyst					
Software Version					
New Password					
Name:					
Date:					
Time:					

IMPORTANT

SERVICE POLICY

Owners of Magnetrol products may request the return of a control; or, any part of a control for complete rebuilding or replacement. They will be rebuilt or replaced promptly. Magnetrol International will repair or replace the control, at no cost to the purchaser, (or owner) **other than transportation cost** if:

- a. Returned within the warranty period; and,
- b. The factory inspection finds the cause of the malfunction to be defective material or workmanship.

If the trouble is the result of conditions beyond our control; or, is **NOT** covered by the warranty, there will be charges for labour and the parts required to rebuild or replace the equipment.

In some cases, it may be expedient to ship replacement parts; or, in extreme cases a complete new control, to replace the original equipment before it is returned. If this is desired, notify the factory of both the model and serial numbers of the control to be replaced. In such cases, credit for the materials returned, will be determined on the basis of the applicability of our warranty.

No claims for misapplication, labour, direct or consequential damage will be allowed.

RETURNED MATERIAL PROCEDURE

So that we may efficiently process any materials that are returned, it is essential that a "Return Material Authorisation" (RMA) form will be obtained from the factory. It is mandatory that this form will be attached to each material returned. This form is available through Magnetrol's local representative or by contacting the factory. Please supply the following information:

1. Purchaser Name
2. Description of Material
3. Serial Number and Ref Number
4. Desired Action
5. Reason for Return
6. Process details

Any unit that was used in a process must be properly cleaned in accordance with the proper health and safety standards applicable by the owner, before it is returned to the factory.

A material Safety Data Sheet (MSDS) must be attached at the outside of the transport crate or box.

All shipments returned to the factory must be by prepaid transportation. Magnetrol **will not accept** collect shipments.

All replacements will be shipped Ex Works.

UNDER RESERVE OF MODIFICATIONS

BULLETIN N°: BE 57-645.1
EFFECTIVE: JULY 2021
SUPERSEDES: August 2015

European Headquarters & Manufacturing Facility

Heikensstraat 6
9240 Zele, Belgium
Tel: +32-(0)52-45.11.11
e-mail: info.magnetrolbe@ametek.com

www.magnetrol.com



MAGNETROL®

AMETEK®