

Tuffy® Liquid Level Controls with Pneumatic Switch

DESCRIPTION

The Magnetrol® Pneumatic Tuffy® Liquid Level Switch is designed for horizontal mounting in a tank or vessel through threaded or flanged pipe connections. The single pneumatic switch mechanism is used for high or low level alarm or control applications.

FEATURES

- All 316 SS wetted components
- Cage pressures to 2200 psig (151 bar)
- NACE and/or ASME B31.3 construction
- Specific gravity as low as 0.40
- 2" NPT mounting
- Process temperatures from -40 to +300 °F (-40 to +149 °C)

TYPICAL INSTALLATION

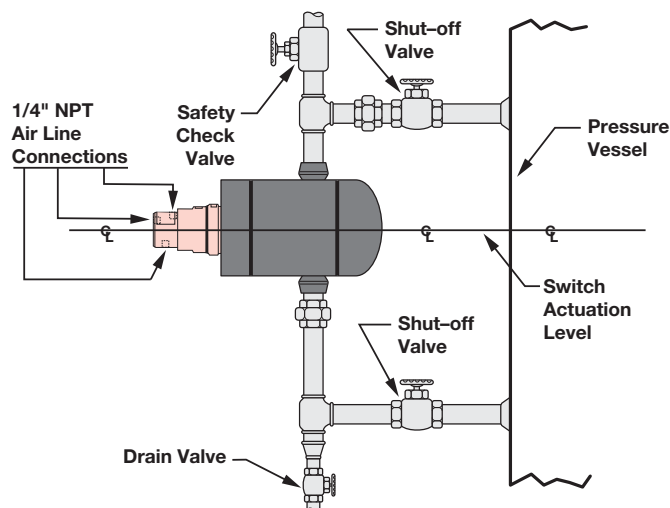

OPTIONS

- Commercially constructed external cage with two 1" NPT top and bottom connections
- ANSI flanges
- NACE or ASME B31.3 external cage with two 1" NPT top and bottom connections available. Consult factory

APPLICATIONS

- Sour service (NACE)
- High/low alarm
- Day storage tanks
- Clean liquids
- Process vessels

PRINCIPLE OF OPERATION

Figures 1 and 2 illustrate the simple Magnetrol® operating principle. Switching action is obtained through the use of a magnet which is attached to a float and a switching mechanism. These two basic component assemblies are separated by a non-magnetic, pressure tight barrier

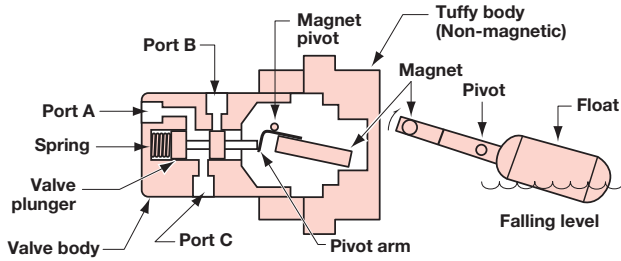

Figure 1
Low Level

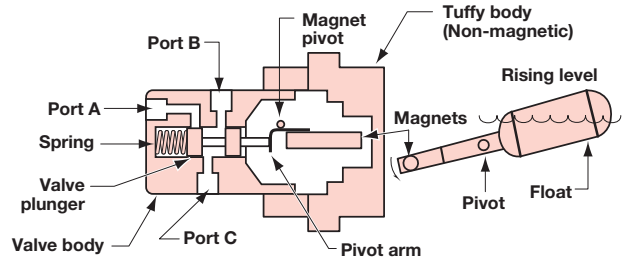

Figure 2
High Level

Port	3-way		Diverter	Selector	2-way	
	N.O.	N.C.			N.O.	N.C.
A	Inlet	Exhaust	Outlet	Inlet	Inlet	Plug
B	Exhaust	Inlet	Outlet	Inlet	Plug	Inlet
C	Outlet	Outlet	Inlet	Outlet	Outlet	Outlet

Note: Orientation of ports may vary from unit to unit.

DIMENSIONAL SPECIFICATIONS

PNEUMATIC SWITCH MODELS

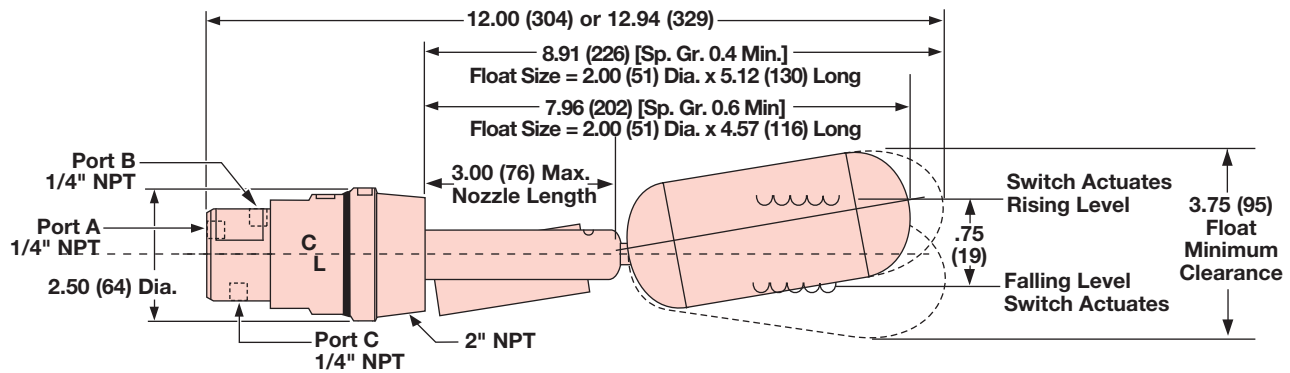

Optional accessories

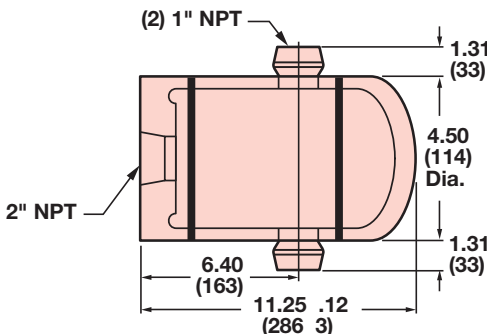

Cage

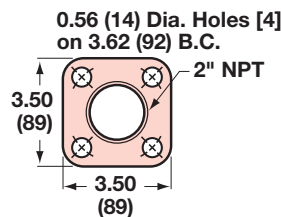

Square Flange

Flange Part No. 04-6804-001
Flange Rating: 250 psig @ +400° F
(17 bar @ +204° C)

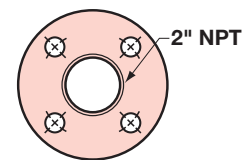

ASME Flange

(Consult factory when ordering)

MODEL NUMBER

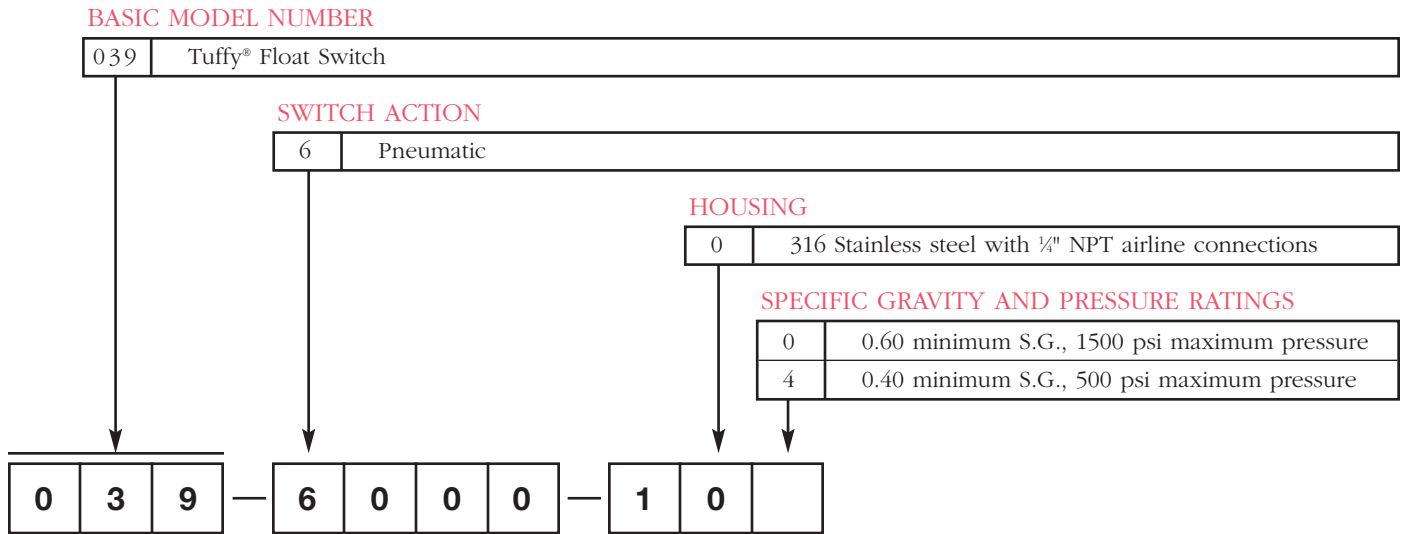

CHAMBER

PART NUMBER

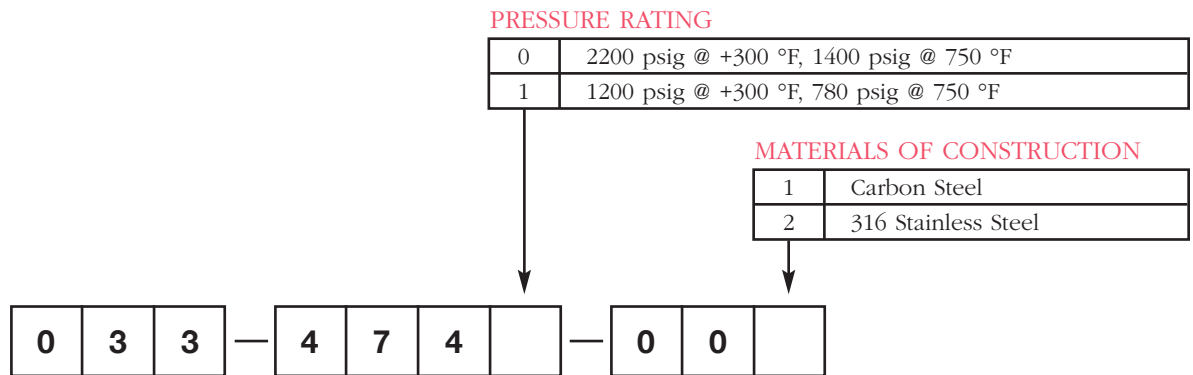

MECHANICAL SPECIFICATIONS

Pressure:	0.6 SG 1500 psig at +300 °F (103 bar at +149 °C) 0.4 SG 500 psig at +300 °F (34 bar at +149 °C)
Process Temperature:	-40 to +300 °F (-40 to 149 °C)
Ambient Temperature:	Max. 100 °F (38 °C) with maximum process temperature
Pneumatic Switch Supply Pressure:	Vacuum to 200 psig (13.8 bar) maximum
Maximum Leakage Rate:	0.5 SCFH (0.015 SCMH @ 100 psig (6.9 bar))
Minimum Air Flow:	2.0 SCFM (0.06 SCMM @ 100 psig (6.9 bar))
Specific Gravity:	0.6 minimum or 0.4 minimum
Materials of Construction:	316/316L SS wetted components including NACE and ASME B31.3
Housing:	316 stainless steel
Cage (optional)	Carbon steel or stainless steel *
Cage Rating	
Schedule 80	2200 psig at +300 °F (151 bar at +149 °C)
Schedule 40	1200 psig at +300 °F (83 bar at +149 °C)

* NACE or ASME B31.3 external cage available. Consult factory.

DESCRIPTION



The quality assurance system in place at MAGNETROL guarantees the highest level of quality throughout the company. Magnetrol is committed to providing full customer satisfaction both in quality products and quality service.

The MAGNETROL quality assurance system is registered to ISO 9001 affirming its commitment to known international quality standards providing the strongest assurance of product/service quality available.

DESCRIPTION



All MAGNETROL electronic level and flow controls are warranted free of defects in materials or workmanship for five full years from the date of original factory shipment. If returned within the warranty period; and, upon factory inspection of the control, the cause of the claim is determined to be covered under the warranty; then, MAGNETROL will repair or replace the

control at no cost to the purchaser (or owner) other than transportation. MAGNETROL shall not be liable for misapplication, labor claims, direct or consequential damage or expense arising from the installation or use of equipment. There are no other warranties expressed or implied, except special written warranties covering some MAGNETROL products.



705 Enterprise Street • Aurora, Illinois 60504-8149 USA
630.969.4000 • info@magnetrol.com • magnetrol.com

Copyright © 2021 AMETEK Magnetrol USA, LLC
Performance specifications are effective with date of issue and are subject to change without notice.

BULLETIN: 44-109.4
EFFECTIVE: September 2016
SUPERSEDES: May 2007